

La Gomera Awning

Technical description

A. General

The La Gomera is a heavy-duty retractable awning. It is designed for sun protection during the day, and ambient temperature control in the evening.

The entire design of the awning is laid out for trouble-free, silent, and safe operation.

The awning frame is available in white (RAL9016) powder coated, or you may request a special color in accordance with RAL.

B. Construction of the Awning

1. Support Bar

The main part of the awning frame is the support bar, which is made from 40x40x2 mm steel sendzimir galvanized and powder coated. The strong back bar extends the mounting choices and prevents twisting.

2. Protection Hood (optional)

The awning hood is made from extruded aluminum, with a thickness of 2 mm. The hood is recommended if the awning is exposed to the weather. It will protect the fabric and frame for a cleaner look.

3. Front Bar

The front bar is made out of an extruded aluminum profile with a wall thickness of 2 mm. It has an oval shape with internal partitions providing a strong rigid bar to keep the fabric straight and taut.

4. End Caps

The front bar end caps are made from durable plastic, powder coated to match the colour and sheen of the aluminum components.

5. Fabric Roller

The Fabric roller is made of a galvanized steel tube with dimensions of 78x1.25 mm to prevent deflection from fabric tension.

6. Folding Arms

The profiles of the arms are made of extruded aluminum profiles with a height of 70 / 65 mm and a sectional thickness of 1.5 mm. The height and oval shape are designed for premium strength.

The heavy duty arms are assembled with three strong torsion springs inside the upper arm profile providing extreme tension for taut fabric and increasing wind resistance while ensuring long term durability. The arms are made with maintenance free stainless steel cables that are covered with PVC tubing for easy cleaning and improved aesthetics.

The upper arm, elbow joint, and lower arm attachment are made by a forged cast aluminum process to combine highest strength yield and design requirements.

All parts are powder coated to offer premium weather resistance and cleaning ability.

7. Slide Support Unit (Shoulder)

The arms are connected to the heavy duty support bar with a slide support unit made of extruded aluminum for superior strength. This patented unit allows for adjusting the pitch of the awning from 0 to 41 Degree. This allows matching the pitch according to mounting height available and desired head room clearance.

8. Front Bar Coupling

The front bar coupling is made from die cast aluminum with a stainless steel joiner that swivels on a stainless steel pin. In accordance with a set screw the pitch of the front bar can be adjusted. Whatever the

pitch of the awning is, the front bar stays straight for better aesthetics.

9. Parts

Various small parts, such as the roller shaft support, tube support brackets, and hood brackets, are made from extruded aluminum. In comparison to cast parts, this increases the durability of the awning and nearly eliminates the breaking of the parts. All parts have rounded edges for smoother appearance and are powder coated. All hardware is stainless steel.

10. Drive

The awning can be operated with either a manual hand crank featuring a smooth bevel gear system with a ratio of 4.4:1 and a limit stop to prevent retracting the fabric the wrong way, or conveniently with a 120 volt tubular motor mounted in the roller tube. The motor can be plugged in an outlet or hardwired and controlled by a switch or remote system. Sun, wind and motion controls are available as well as a manual override option for the motor.

11. Fabrics

The fabric consists of a woven acrylic material having a weight of approximately 300 g/sq.m, and is sewn together in 120 cm wide panels.

Swelacryl Fabric: Swelacryl awning fabrics are made from spun-dyed, rot-resistant, polyacrylic fibers, which are highly tear-resistant and ultra colorfast. For durability and performance, Swela uses quality 8.55 oz/sq. yd (290 g/sq. m) fabric, and employs a

process where the fabric is finished with DuPont Teflon. This combination means that Swelacryl fabrics have a water pressure resistance of 35 mbar (350mm) according DIN 53886.

Swela SunsilK Fabric: Swela SunsilK awning fabrics are made from specially dyed, light-fast and UV-stable polyester yarn, highly tear-resistant and UV-stable due to a special UV absorber. Due to the SNC (Swela Nano Clean) finish, dirt can be removed just by rinsing down with water or rain. The water pressure resistance according to DIN 53886 of 50 mbar (500mm) is much better than acrylic fabrics. Due to being 30% thinner than conventional fabrics, there is less accumulation and drop between seams. It simply looks nicer.

12. Mounting Brackets

There are mounting brackets available for various mounting options to accommodate the customer's situation.

Wall bracket: The wall brackets are made from extruded aluminum for optimum strength to ensure that the awning is secure.

Soffit bracket: The soffit brackets are made from extruded aluminum for optimum strength. It can be attached to the wall brackets to mount the awning to the top.

Joist bracket: The joist brackets are made from extruded aluminum for optimum strength. It can be attached to the wall brackets to mount the awning to the joists.

Roof bracket: The roof brackets are made from steel for optimum strength. The adjustable angle allows installation on top of any roof with various slopes.

C. Technical Possibilities

The width of the awning is custom made from 7' ¾" (215 cm) to 39' (1200 cm) (see also minimum width for projections)

The Projection is available in: 5' (150 cm), 6'6" (200 cm), 8'2" (250 cm), 10' (300 cm), 11'6" (350 cm), and 13'2" (400 cm) (not for ShadePlus, PitchAdjust and CrossOver).

La Gomera

Minimum Overall Awnings Width for Arm Projection – without Hood						
Projection (cm)	5' (150)	6'6" (200)	8'2" (250)	10' (300)	11'6" (350)	13'2" (400)
Min. Width (cm)	6'10 5/8" (210)	8' (244)	9'7 7/8" (294)	11'3 1/2" (344)	12'11 1/8" (394)	14'6 7/8" (444)

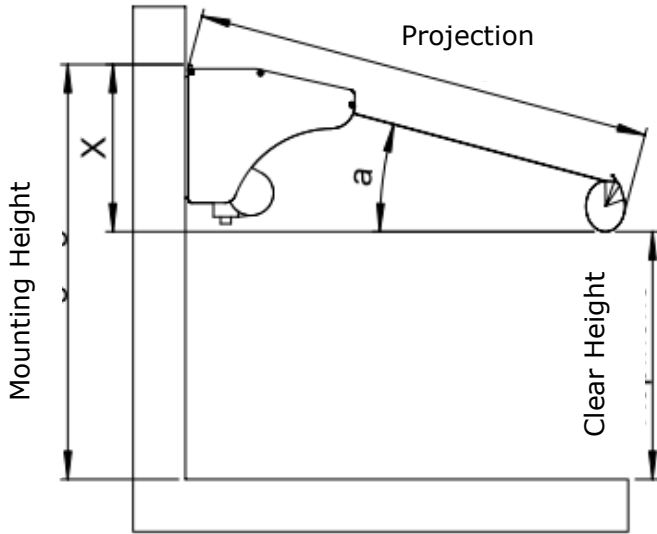

Width	# of Brackets
<12' (366 cm)	3
12' - 17' (518 cm)	4
17' - 21' (640 cm)	5
21' - 23' (700 cm)	6
23' - 29' (884 cm)	7
29' - 33' (975 cm)	8
33' - 36' (1000 cm)	9
36' - 40' (1200 cm)	10

Pitch	Projection (cm)					
	5' (150)	6'6" (200)	8'2" (250)	10' (300)	11'6" (350)	13'2" (400)
	Height X (mm)					
5°	10 3/8" (263)	12" (306)	13 3/4" (350)	15 1/2" (394)	17 1/4" (437)	19" (481)
10°	15" (383)	18 1/2" (470)	22" (557)	25 3/8" (644)	28 3/4" (731)	32 1/8" (818)
15°	19 3/4" (502)	24 7/8" (631)	30" (761)	35" (890)	40 1/8" (1020)	45 1/4" (1149)
20°	24 3/8" (618)	31" (789)	37 3/4" (960)	44 1/2" (1131)	51 1/4" (1302)	58" (1473)
25°	28 3/4" (730)	37" (942)	45 3/8" (1153)	53 3/4" (1364)	62" (1575)	70 3/8" (1787)
30°	33" (838)	42 7/8" (1088)	52 5/8" (1338)	62 1/2" (1588)	72 3/8" (1838)	82 1/4" (2088)
35°	37" (940)	48 3/8" (1227)	59 5/8" (1514)	70 7/8" (1801)	82 1/4" (2088)	93 1/2" (2374)
40°	40 7/8" (1037)	53 1/2" (1358)	66 1/8" (1680)	78 3/4" (2001)	91 3/8" (2322)	104" (2644)
Mounting Height = Clear Height + X						

Mounting Brackets

Wall Bracket

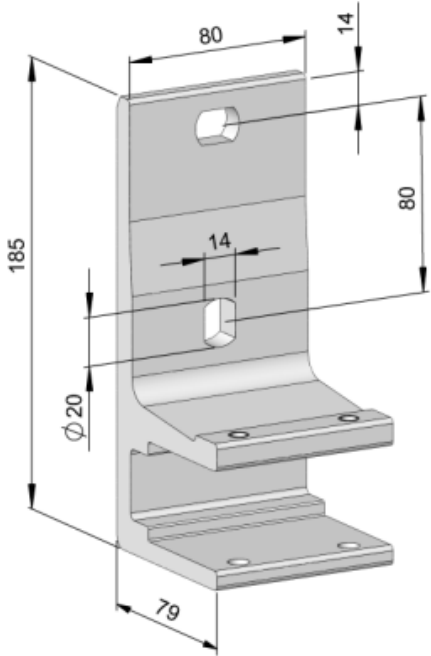

Joist Attachment

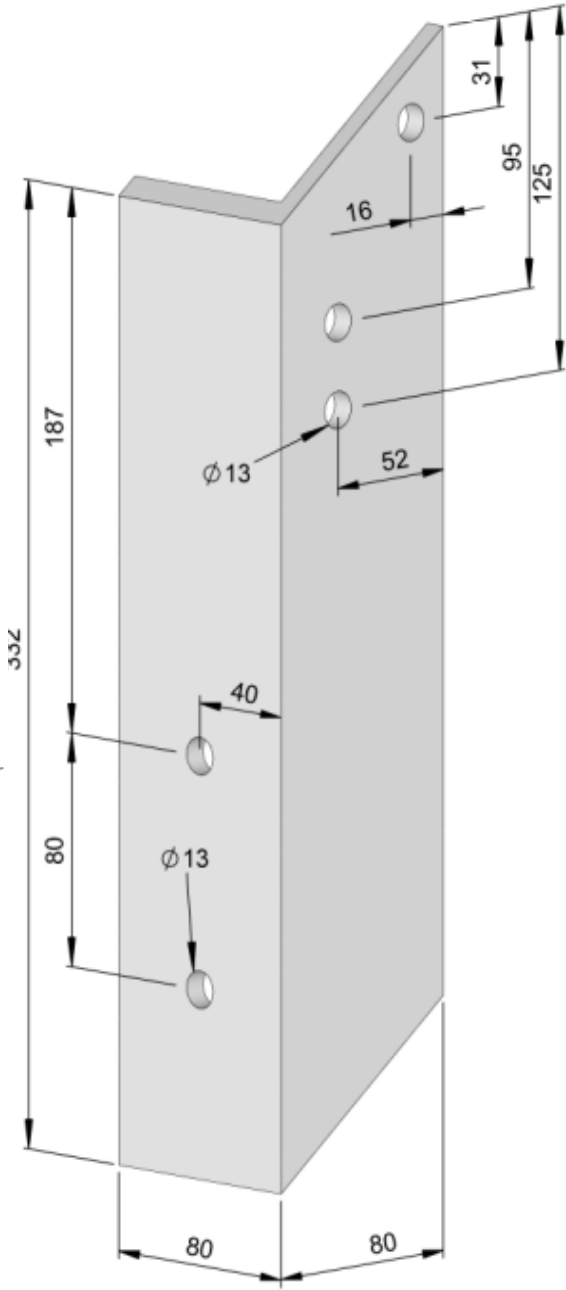

Soffit Bracket

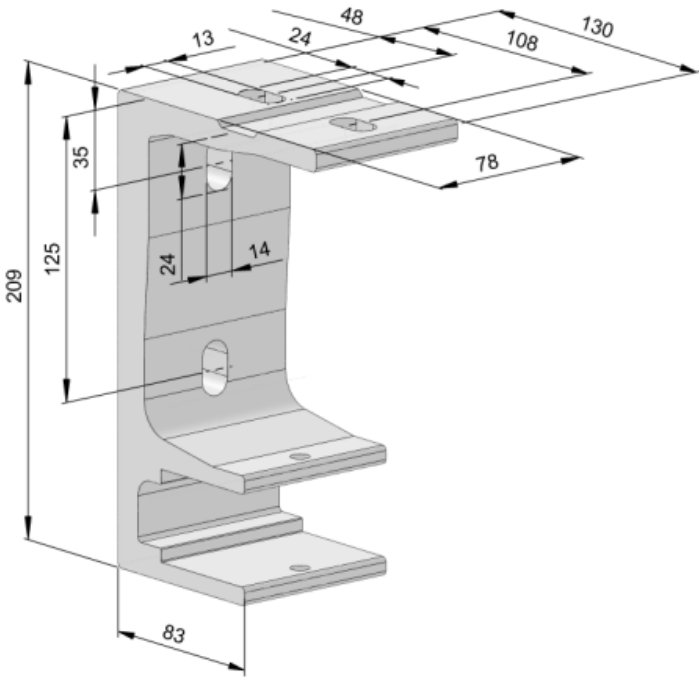

Installations

Wall Mount

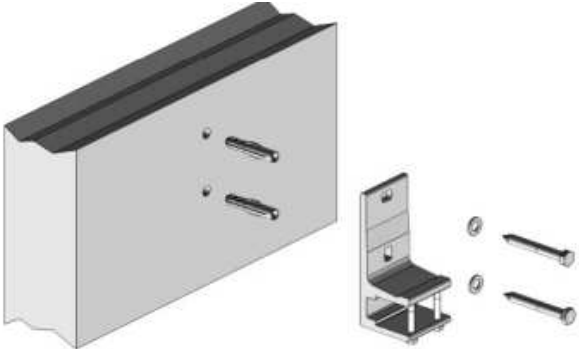
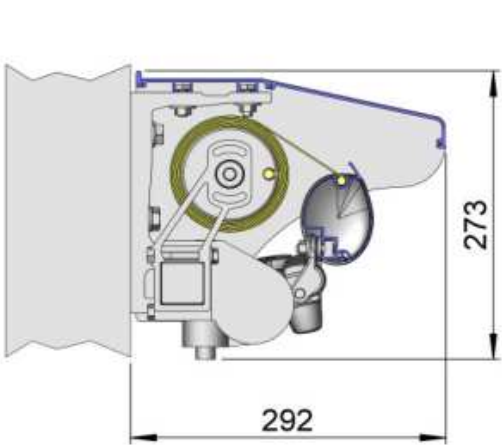

Soffit Mount

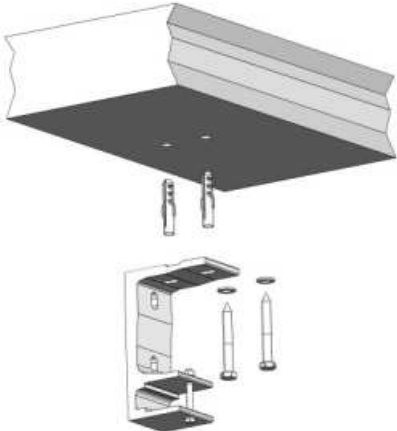
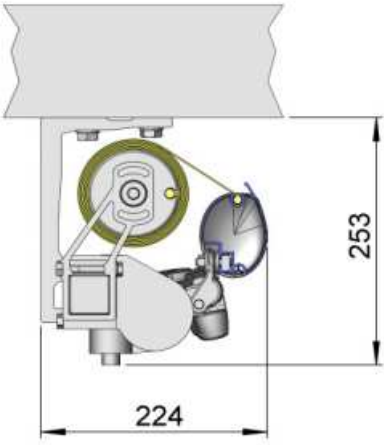

Joist Mount

